

# Automatisering av sperreprosessen

Seafood Automation A/S

Lars Lyngaas  
Jon Ulfsrud

# Seafood Automation AS



seafood automation

## Branding and Traceability

Made easy with automatic tagging

Quality, precision and creativity

FishTag  
TracePin



BaccoTag



Bacallau Creschi  
Singapore Export, Address:  
Batch: 52735 Pack date:  
Keep Good: +2 (+8 10 7 8



3122007110

# Vårt hovedprodukt, maskiner for "branding" og sporbarhet.



Bacalhau da Noruega?



Certifique-se que escolhe o verdadeiro.

Lorem ipsum dolor sit amet, consectetur adipiscing elit. Phasellus cursus porttitor metus, sit amet aliquet mauris. Piacent a. Do nec scelerisque bibendum to ror ki cursus. Nunc et vestibulum est. Lorem ipsum dolor sit amet, consectetur adipiscing elit. Sus pendare dolor elit, gravida quis faucibus vitae, tringilla eu purus.



www.mardanoruega.com

The advertisement features a blue header with the text "Bacalhau da Noruega?". Below this is a circular logo with the word "NORGE" and "PRODUTO DO MAR DA NORUEGA" around a fisherman. The main text asks "Certifique-se que escolhe o verdadeiro." followed by a block of placeholder text. The bottom half of the ad shows several pieces of dried fish with tracking tags attached. The tags include the "NORGE" logo, the text "BACALHAU DA NORUEGA", and "MARDANORUEGA". One tag also features the text "CARE FOR FISH" and "JANGAARD". The website "www.mardanoruega.com" is listed at the bottom.

# Proessen automatisert sperring

- Ide og pådriver Jon Edvard Johansen, Hovden Fiskeindustri.
- FHF v/ Frank Jacobsen og Lorena Gallert Jornet.
- Prosjekt finansiert av FHF, Innovasjon Norge, Røst Sjømat(pilot) og Seafood Automation A/S
- Intens utvikling, testing av alle prinsipper og moduler, i lab og i produksjonsmiljø.
- Innspill fra prosjektgruppen og andre aktører til utviklingen
- Sperringer foretatt og hengt på hjell på Røst 8 Februar.

# Prosjektet løsnings ide.

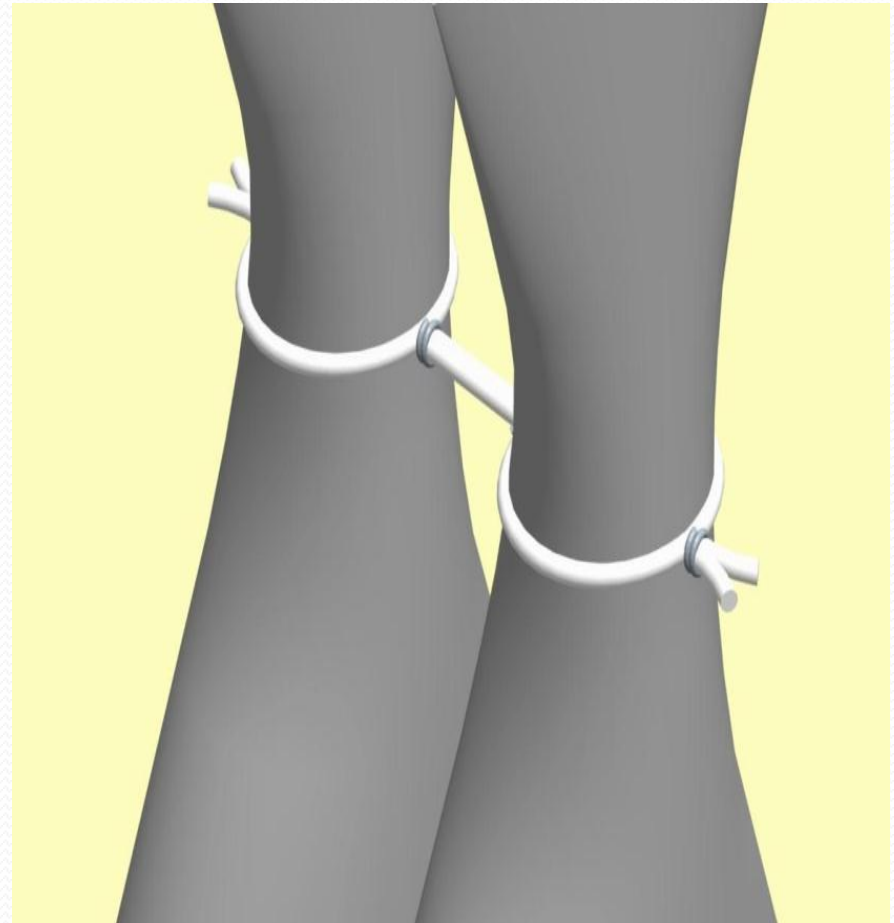
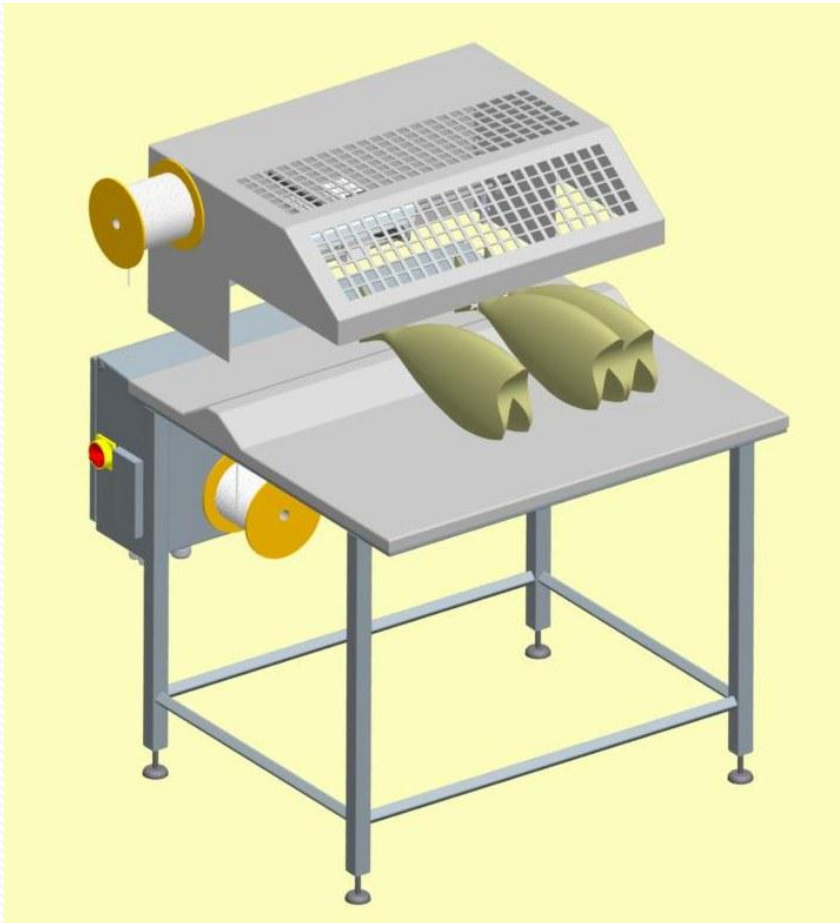

# Test produksjon på Røst



# Test hos Røst Sjømat

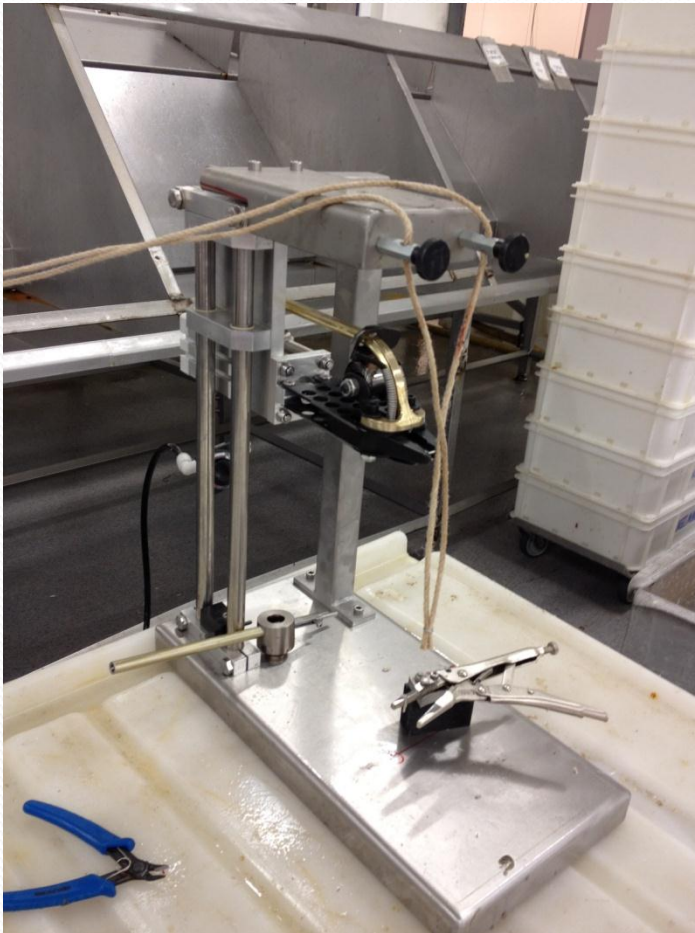

# Røst 8 februar

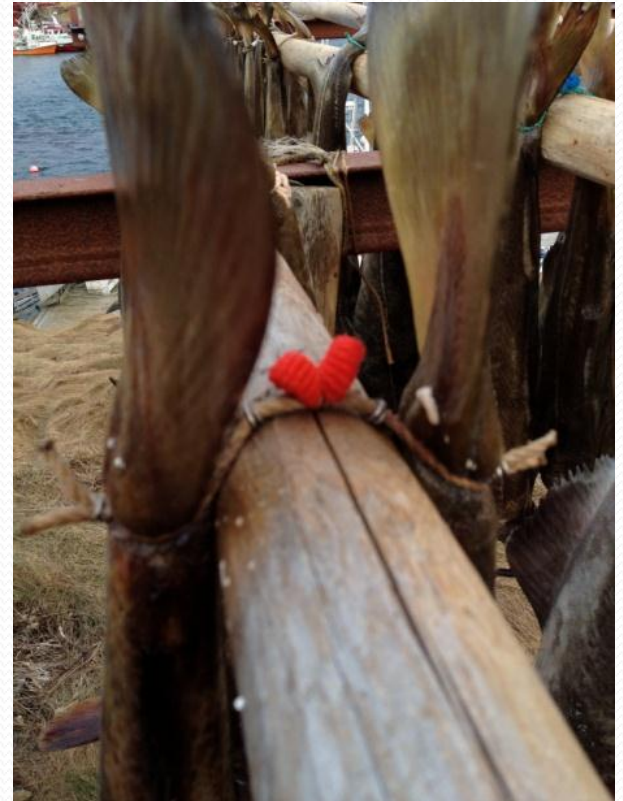



# Ferdig prototype løsning. "SPERRO"

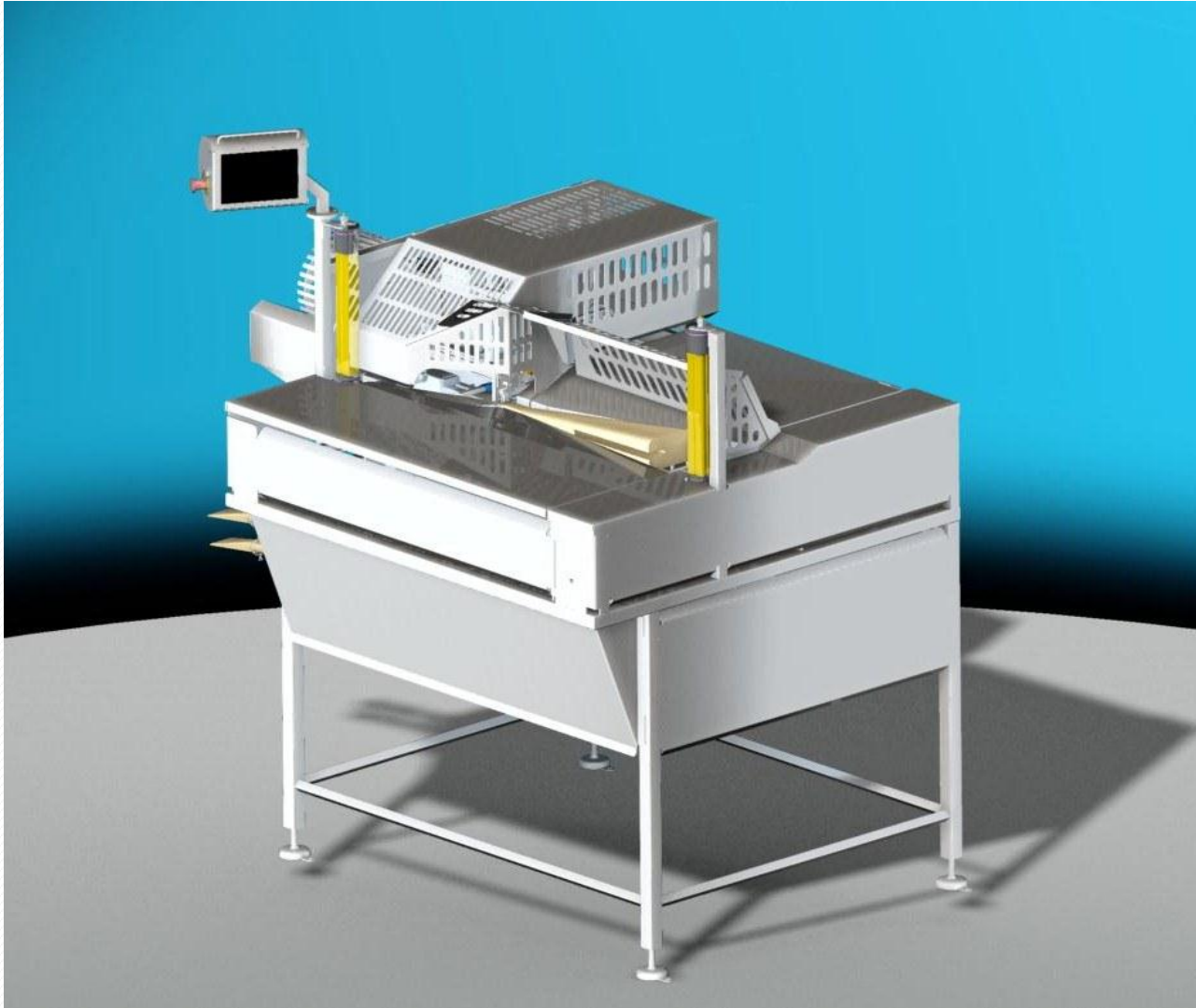

# "SPERRO"

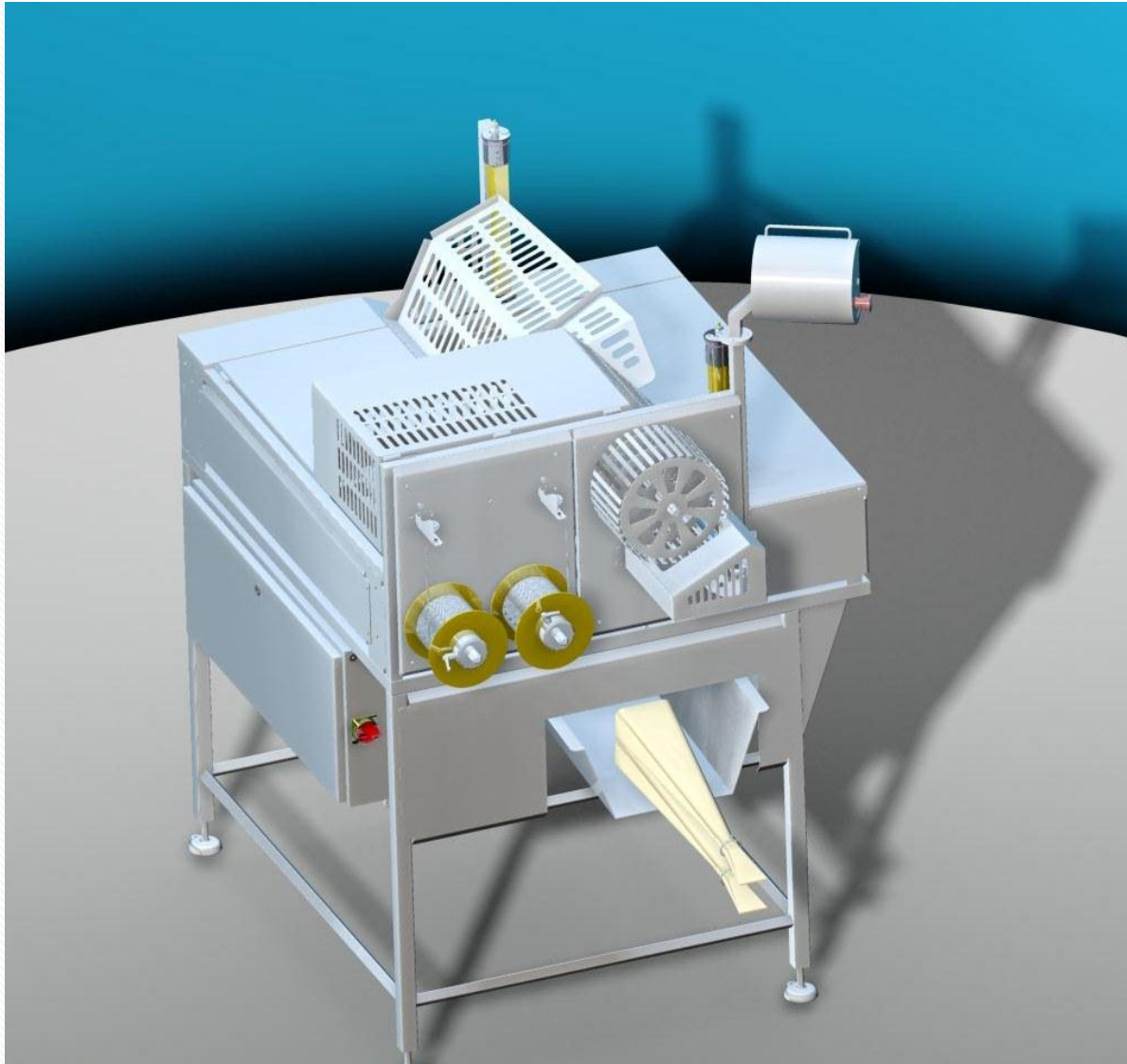

# “SPERRO”

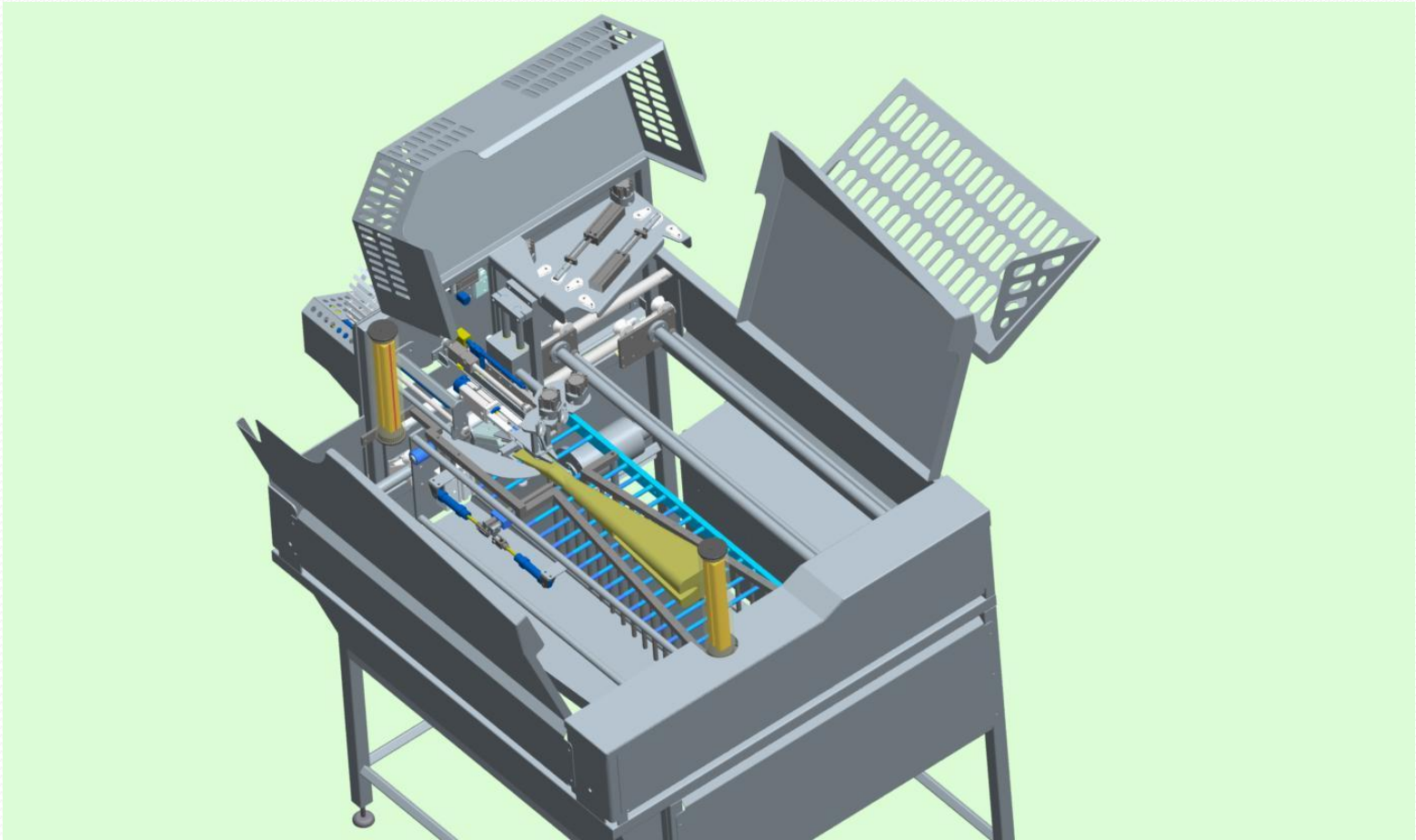

# Forslag til produksjonslinje



# Arbeitsstilling

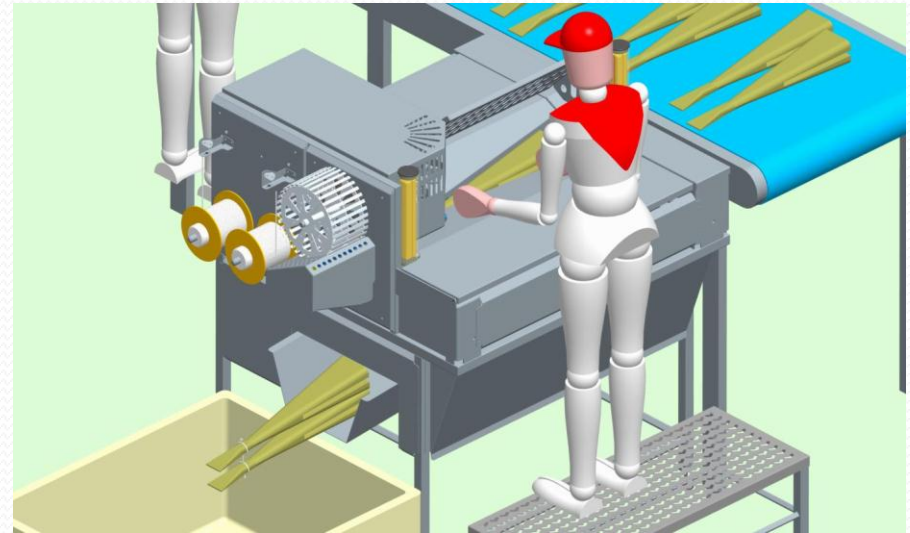
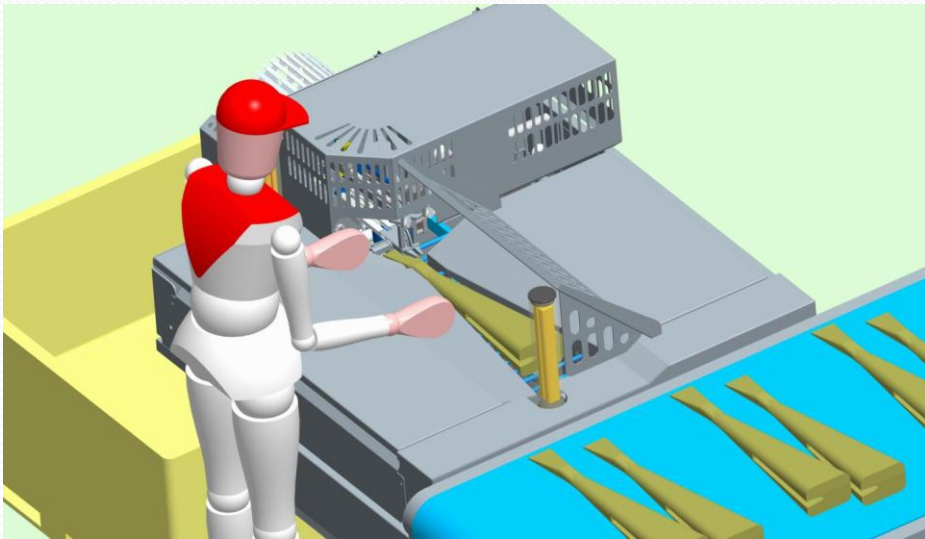

# Fordeler

- Redusert bemanning
- Fjerner tung arbeidsprosess
- Enkel å bruke, minimal opplæring
- Jevne, sikre sperringer
- Skånsom prosess, reduserer slag på fisken

# Effektivitet

- 10+ sperringer /min
- Arbeider kontinuerlig.
- Kapasiteten er tilgjengelig hele året.
  
- 2 mann+ 1 maskin gjør 5 manns arbeide.
  
- 3 mann + 2 maskiner, gjør 10 manns arbeide.

# Sporbarhet

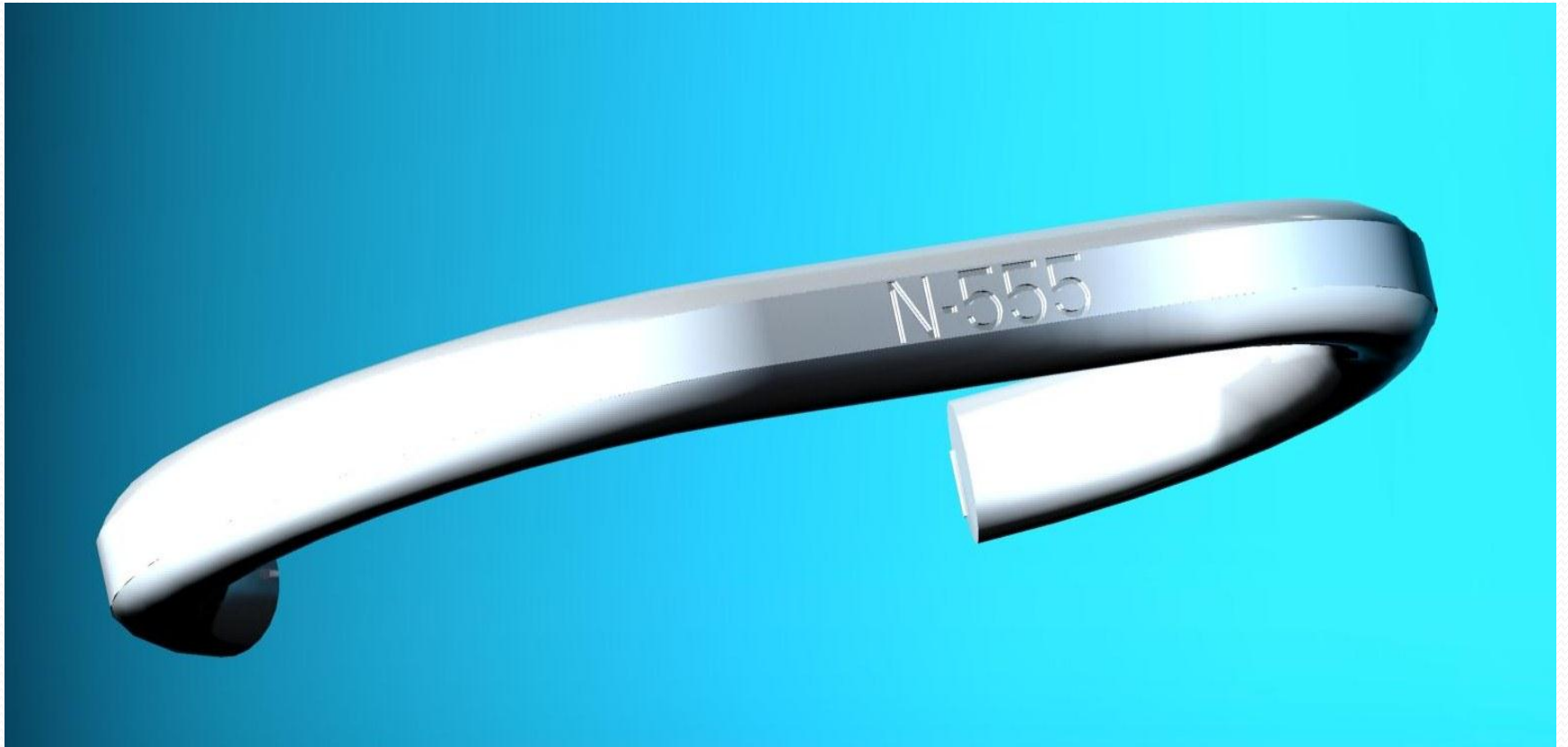



# Hvorfor sporbarhetsmerking?

- Sporbar gjennom verdikjeden
- Hver bedrift, sin identitet
- Sikkerhet ved reklamasjoner
- Oppfyller fremtidige krav
  
- Muligheten finnes i maskinen.

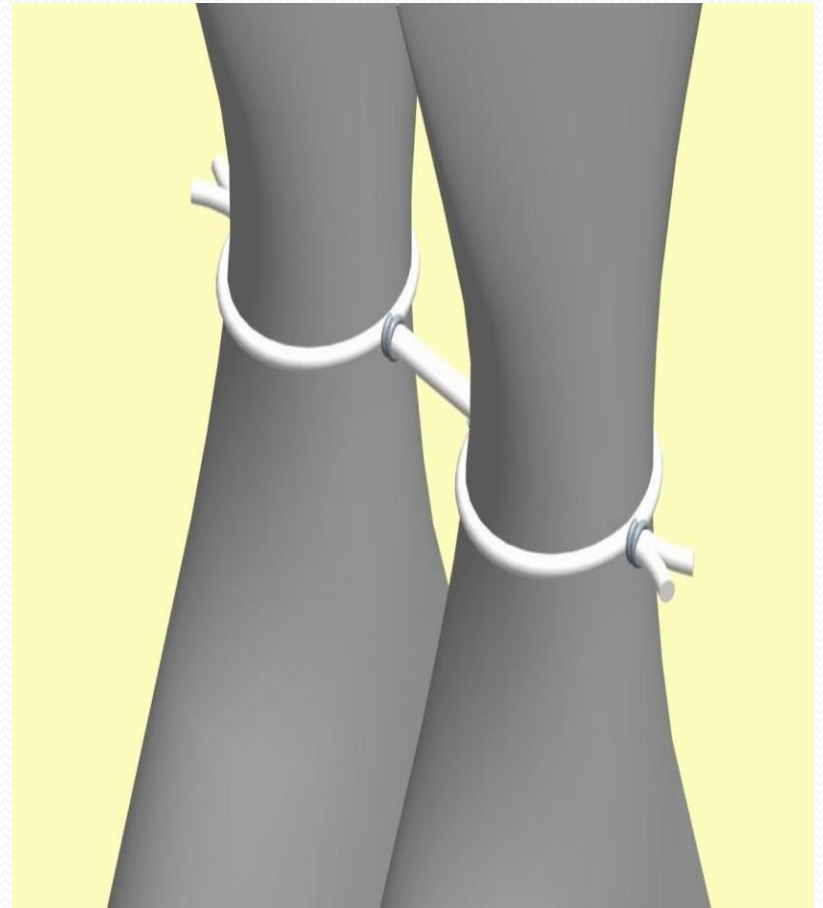

# Veien fremover.

- Alle deltester og resultater gjør oss sikre på at dette blir en solid og effektiv maskin.
- Prototype demo på Røst, medio August.
- Bestillingpunkt 14 dager etter dette.( kun 1 serie før sesongen)
- Levering 1. uke i Januar.
- Prisen er med et fornuftig produksjonsvolum, målsatt til å bli 480.000.-

# Interesse?

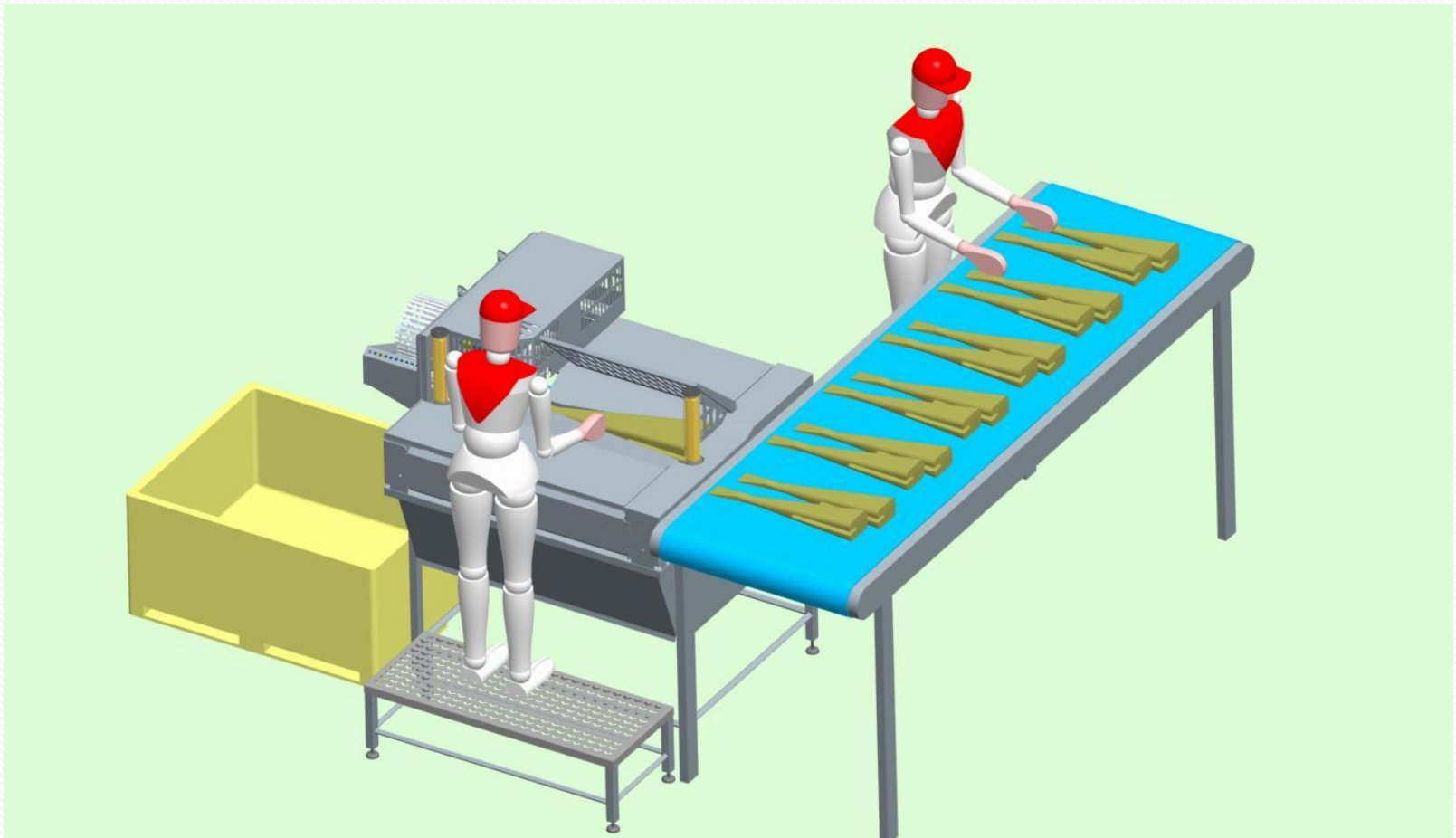

- design to the bone

